

Auto Tool Change Ultrasonic Servo Motor Spindle

AUSMS50 - CO - 0.4KW - 0.75K

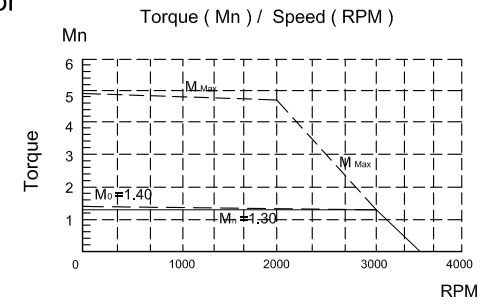
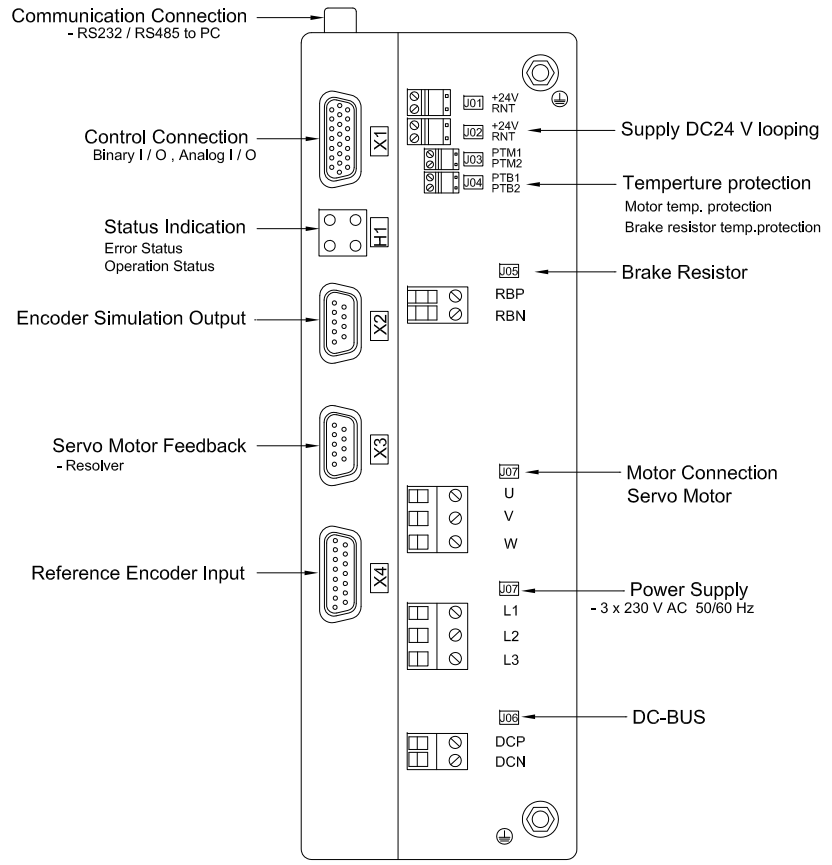
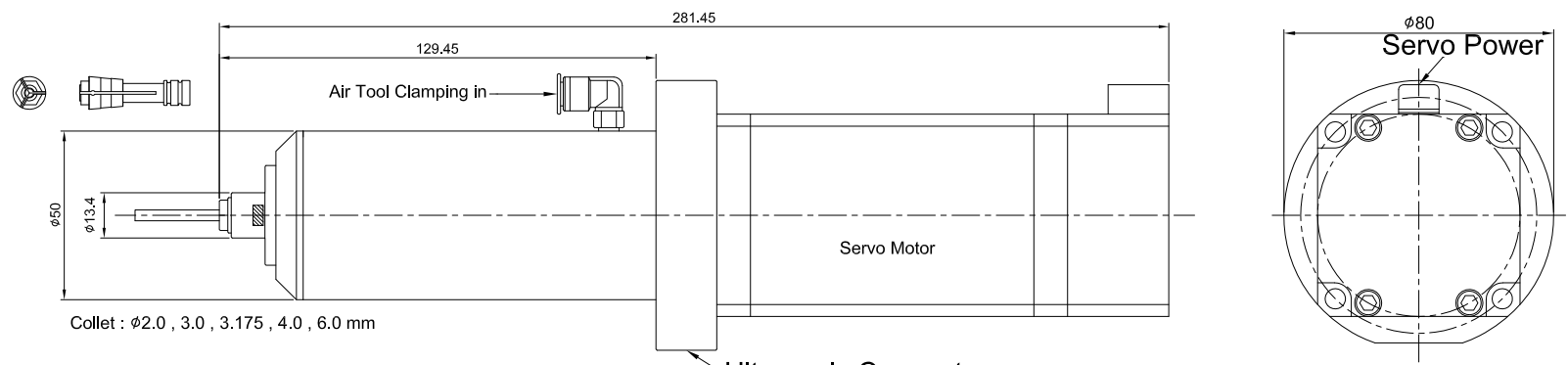

Servo Motor

Specification	Code	Unit	Technical Data	Reduction Ratio 4:1
Rate Speed	N _N	rpm	3000	Output 750
Rate Power	P _N	Kw	0.4	
Rate Torque	M _N	Nm	1.3	Output 5.2
Rate Voltage	V _N	V	190	
Rate Current	I _N	Amp	1.55	
Max. Speed	N _{Max.}	rpm	3500	
Zero Speed Torque	M _N	Nm	1.4	
Voltage Constant	K _E	V/Krpm	56.70	
Torque Constant	K _T	Nm/Amp	0.63	
Terminal motor resistance	R _{2ph}	ohm	15.2	
Terminal motor inductance	L _{2ph}	mH	41	
Rotor Inertia	J	kg.m ²	0.62E-04	
Feedback Device	-	-	Resolver	
Ambient Temperature	-	C°	0 ~ 40	
Insulative Class	-	-	F . H	
Humidity	-	%	< 90	

The manufacturer has the power to change the performance and appearance dimensions. The change is made to the advanced method of the product.